

Submittal Data Sheet

SER11504N

Fantech Commercial Energy Recovery Ventilator Ducted Indoor Model

Features

- Energy recovery core
- Backward inclined motorized impeller
- Dual service doors & Reversible electrical box
- Push-push configuration
- External electrical box
- Electrostatic filters
- External low voltage contacts
- Outdoor ducts on the same side



Options & Controls

- MERV6 rated filters
- Compatible with all Fantech HRV/ERV controls

Job Name:		
Job Location:		
Job Reference Number:		
Unit Reference Number:		
Engineer:		
Distributor:		
Contractor:		
For Reference:	For Approval:	For Construction:
Submitted by:		Date:
Address:		
Tel:	Fax:	Email:
Notes:		



United States · 1712 Northgate Blvd. · Sarasota FL 34234 · 1-800-747-1762 · www.fantech.net
Canada · 50 Kanalfakt Way. · Bouctouche, NB E4S 3M5 · 1-800-565-3548 · www.fantech.ca

Fantech, reserves the right to modify, at any time and without notice, any or all of its products features, designs, components and specifications to maintain their technological leadership position.

SER11504N Submittal Data, Fantech Commercial Energy Recovery Ventilator

Descriptions

- Case:** 20 gauge G90 galvanized steel sheet coated with baked powder paint, insulated with 25mm (1 inch) foil-faced high density polystyrene foam for condensation control.
- Blowers:** Four maintenance-free Ebm-Papst™ backward inclined motorized impellers with permanently lubricated sealed ball bearings and (TOP) thermal overload protected.
- Energy recovery core:** The energy recovery core is manufactured from a flame-proof/Polyester-based synthetic paper which is designed to transfer sensible and latent heat. During winter, the core transfers heat and moisture from the outgoing air to the incoming fresh air and during summer the core transfers heat and moisture from the incoming air to the outgoing air to essentially reduce the cooling load.
- Filters:** The exhaust and fresh air streams are protected by MERV1 washable filters constructed to meet UL Class2. Optional MERV6 filters are direct replacement to the MERV1. Use of MERV6 filters will add an additional system pressure of 72 Pa (0.29in.wg) at 543 l/s (1150cfm).
- Controls:** External three (3) position (Low / Standby / Medium) rocker switch that will offer continuous ventilation. Compatible with all Fantech HRV/ERV controls.
- Serviceability:** Unit has hinged or screwed access panels on front and back. Cores, filters & motors are serviceable from either sides of the unit. Fan assemblies are mounted on a removable sliding base. Energy recovery cores are mounted in slide-out rails for ease of inspection, removal and cleaning. Accessibility to the electrical box is maintained for any unit installation.
- Mounting:** Unit can be rod mounted or seated on a platform. Flanged connections are provided for suitable ductwork connections. Unit shall be adaptable for easy service of electrical components.
- Warranty:** The Energy recovery ventilator is warranted to be free from defect in material, workmanship and all parts for a period of 3 years from the purchase date. The energy recovery core is warranted to be free from defects in material and workmanship for a 5 years period under circumstances of normal use.

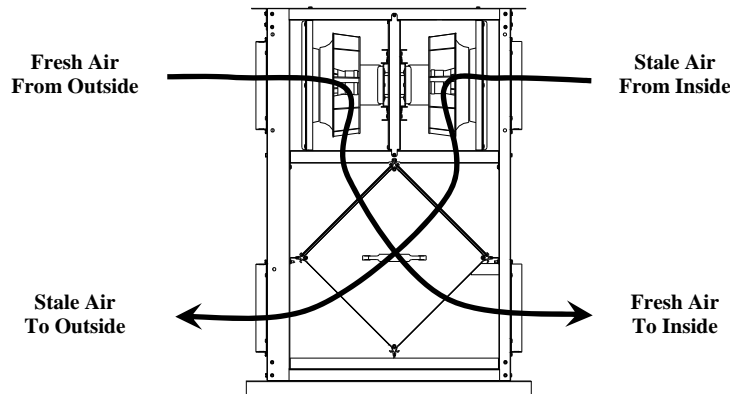

United States · 1712 Northgate Blvd. · Sarasota FL 34234 · 1-800-747-1762 · www.fantech.net
Canada · 50 Kanalfakt Way. · Bouctouche, NB E4S 3M5 · 1-800-565-3548 · www.fantech.ca

Fantech, reserves the right to modify, at any time and without notice, any or all of its products features, designs, components and specifications to maintain their technological leadership position.

SER11504N Submittal Data, Fantech Commercial Energy Recovery Ventilator

Specifications

- Volts 120V
- Phase Single
- Amperage 10.8 Amps Total
- Blowers (x4) 115V, 60Hz, 2.7Amps



- Weight 96Kg (212Lbs)
- Shipping Weight 114Kg (252Lbs)
- Shipping Dim. 674x1422x946mm(27x56x37.5")

Airflow Performance

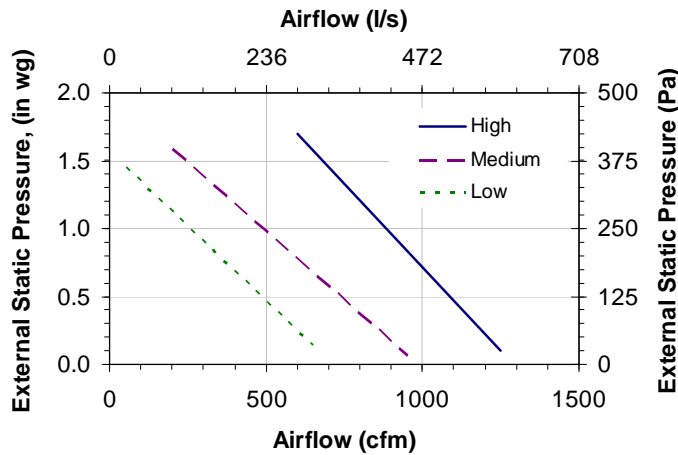

Effectiveness

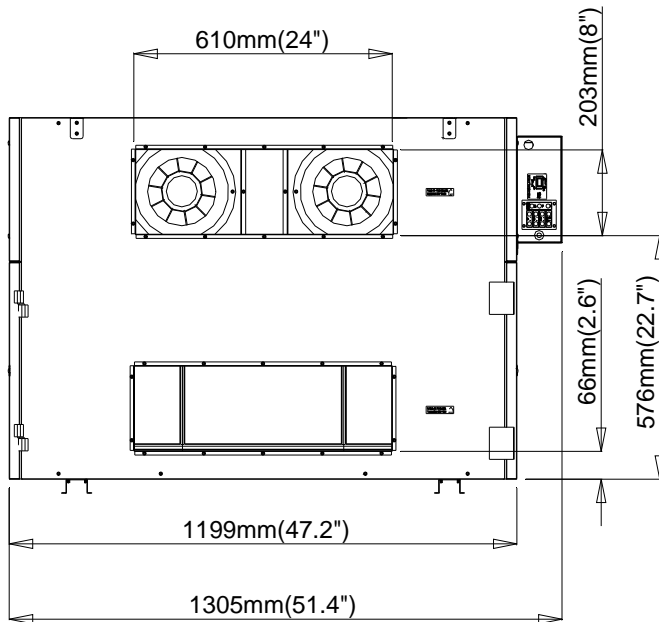
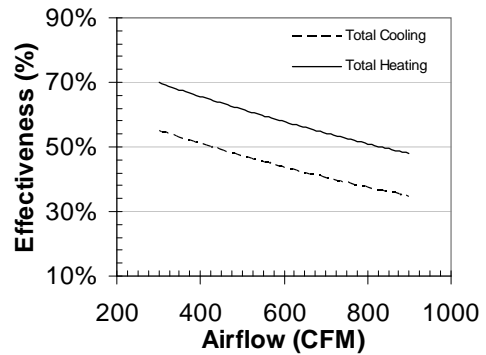

ELECTRIC BOX(can be relocated in the field to either the front or the back of the cabinet)

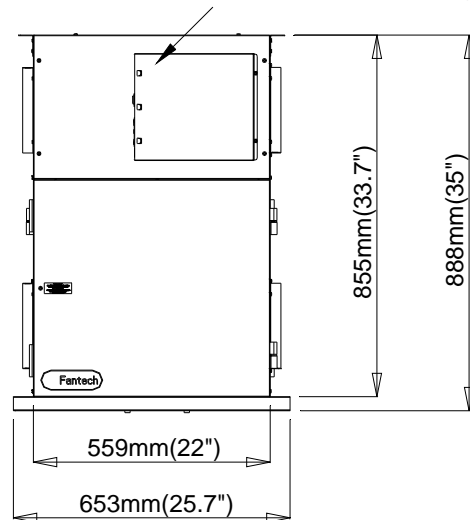

United States · 1712 Northgate Blvd. · Sarasota FL 34234 · 1-800-747-1762 · www.fantech.net
 Canada · 50 Kanalfakt Way. · Bouctouche, NB E4S 3M5 · 1-800-565-3548 · www.fantech.ca

Fantech, reserves the right to modify, at any time and without notice, any or all of its products features, designs, components and specifications to maintain their technological leadership position.